

Zumaiako arau subsidiarioen
BERRIKUSPENA
REVISION
de las normas subsidiarias
de ZUMAIA.

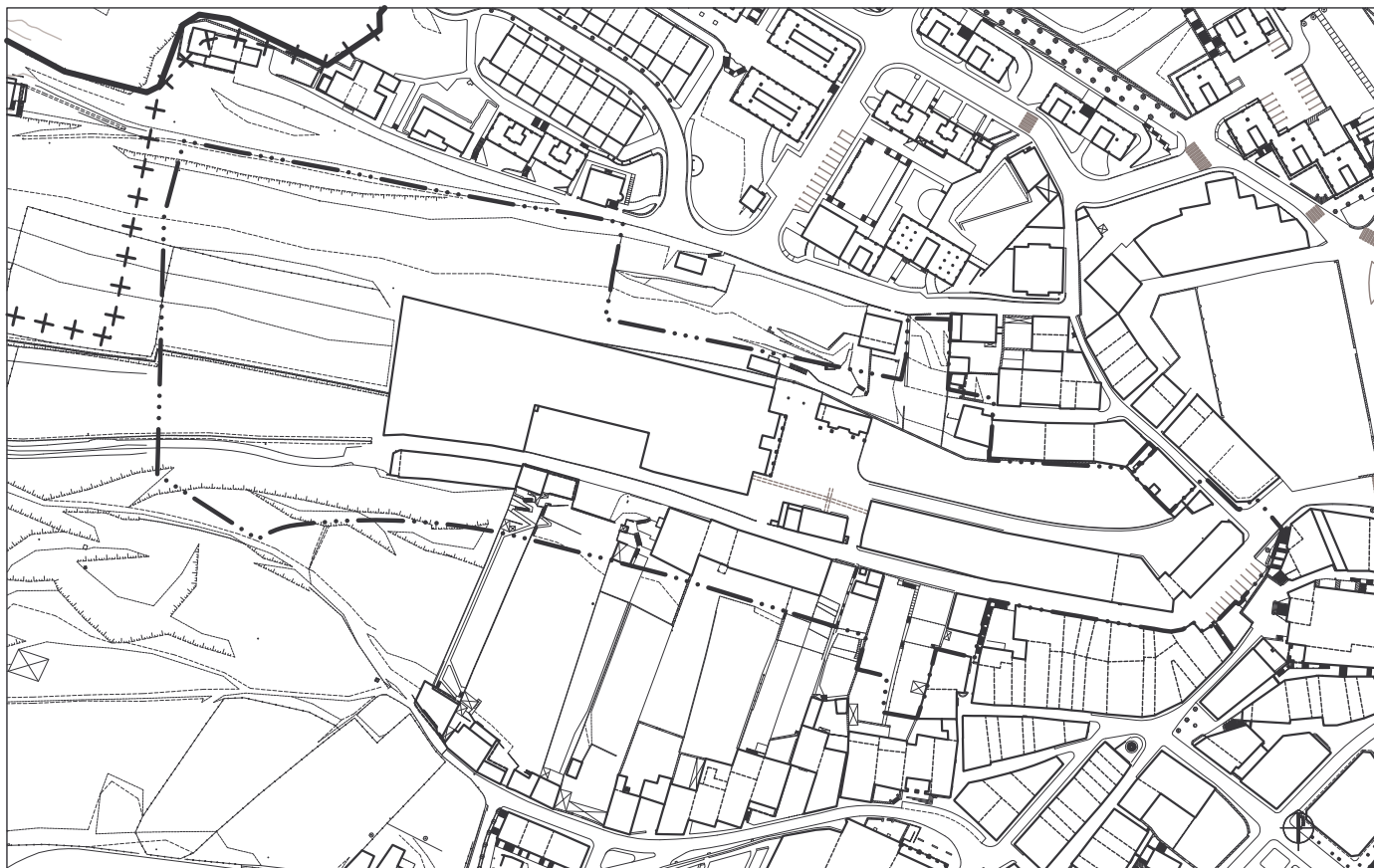

Zumaiako Udala

A.U.07
ARDANTZABIDE



EGUNGO EGOERA. ESTADO ACTUAL.

ESCALA 1:2.500 ESKALA

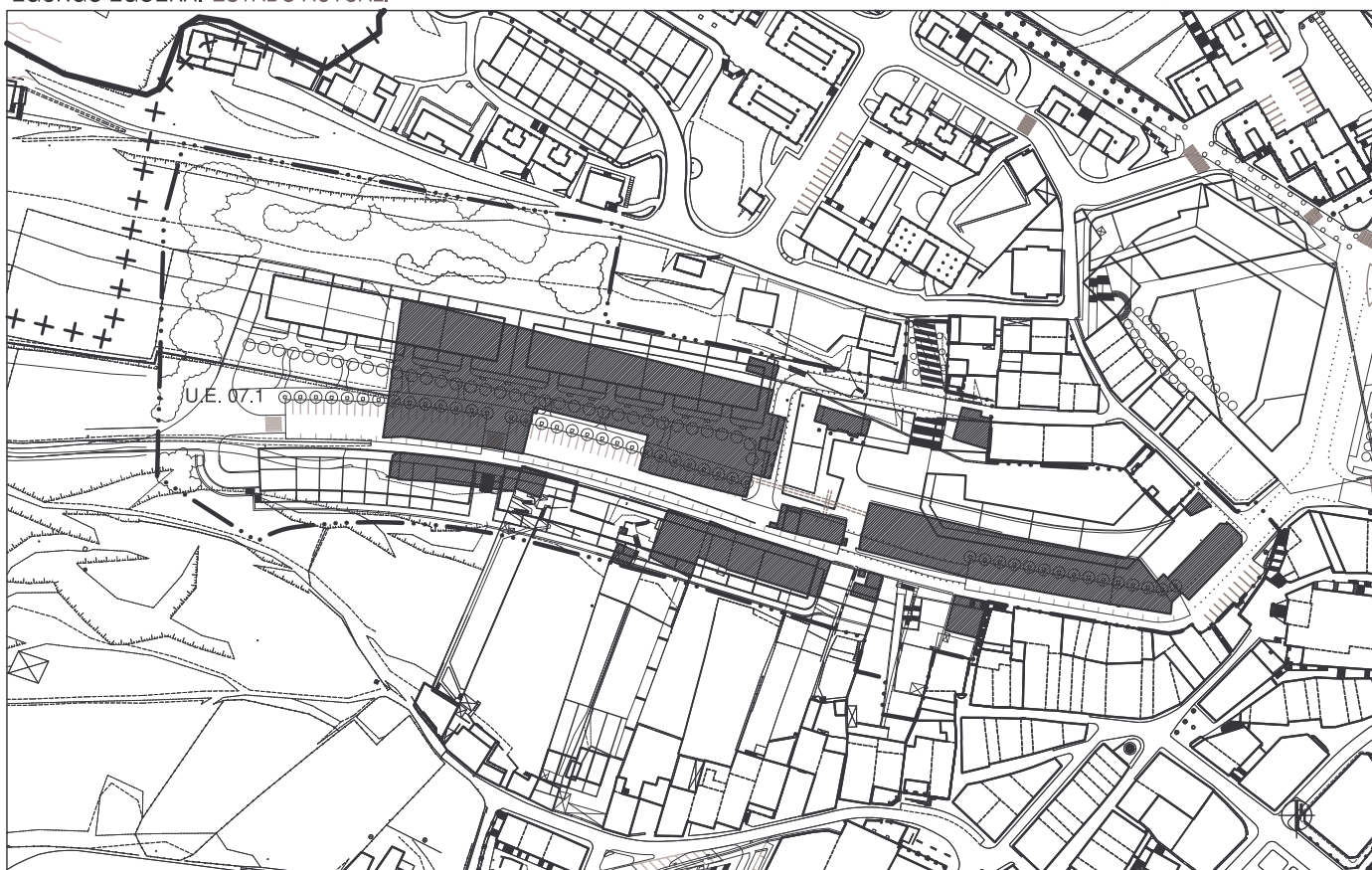

ANTOLAMENDUA / EGUNGO EGOERA GAINEZARPENA. SUPERPOSICION ORDENACION / ESTADO ACTUAL.

ESCALA 1:2.500 ESKALA

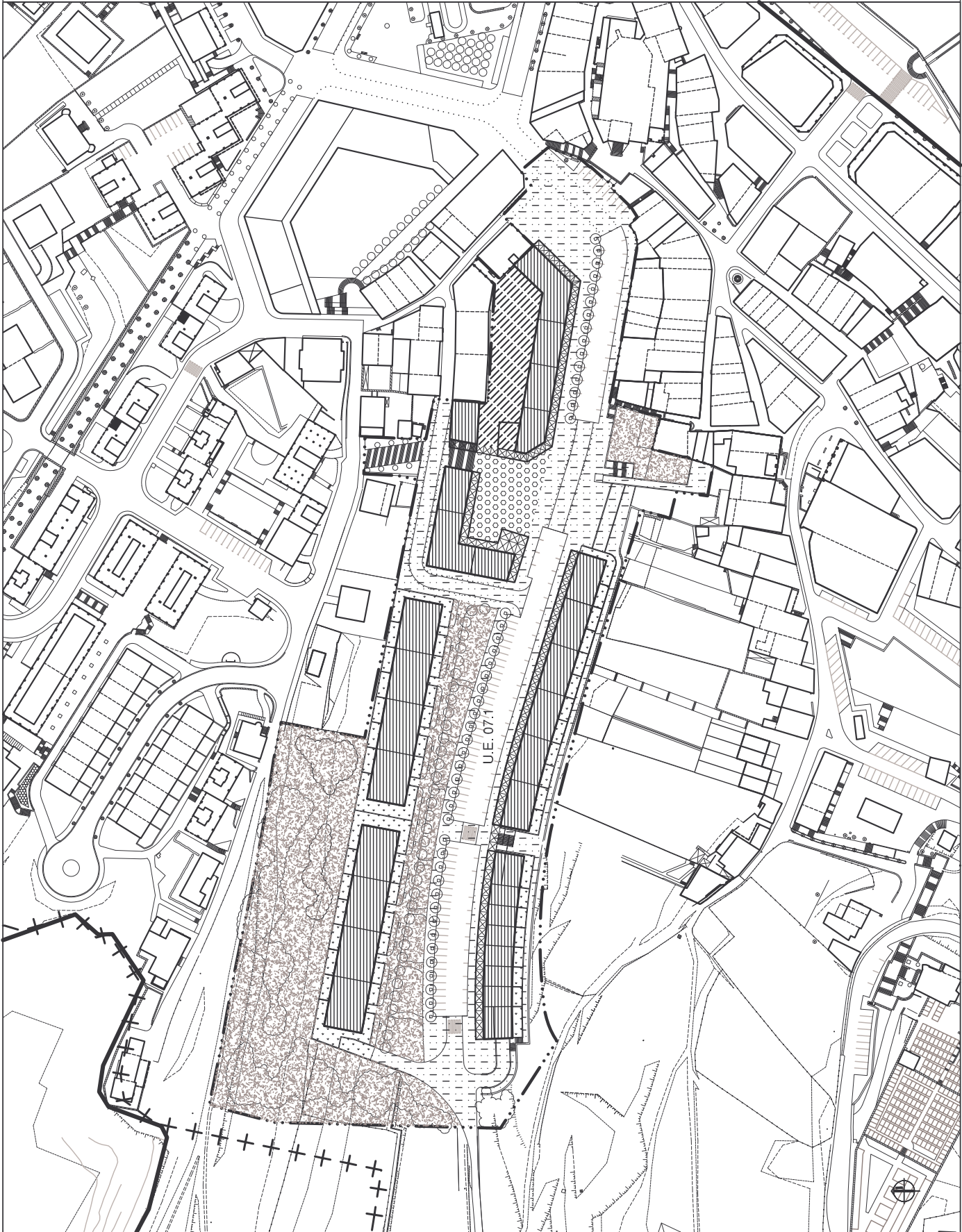
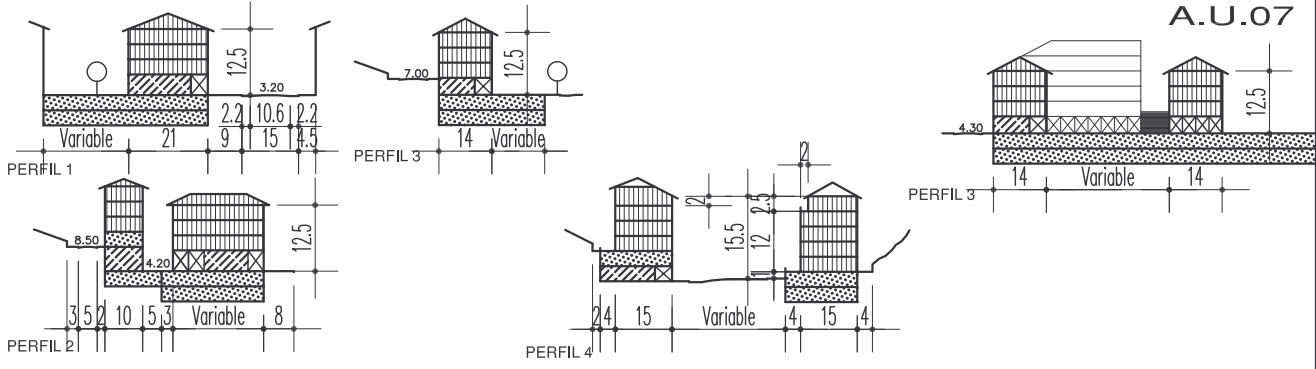

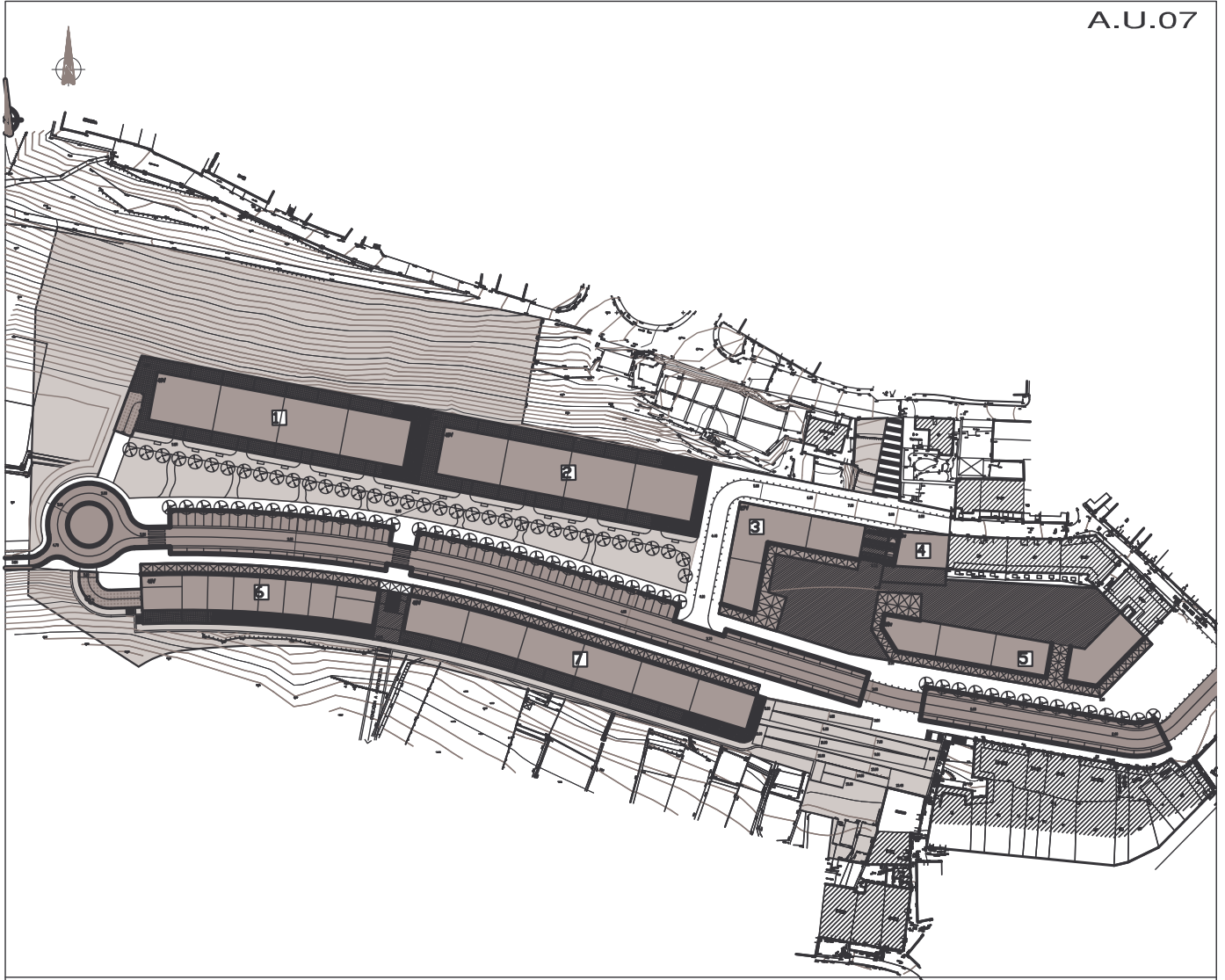

USOS PORMENORIZADOS

PARCELAS DE PROPIEDAD Y USO PUBLICO.

■ SISTEMA LOCAL DE ESPACIOS LIBRES.

SISTEMA DE RED VIARIA:

■ CALZADA DE RODADURA Y APARCAMIENTOS ANEJOS
 □ ACERAS, PASEOS PEATONALES.

PARCELAS PRIVADAS.

- PARCELAS RESIDENCIALES EN BLOQUE.
- PARCELA PRIVADA CONSTRUIDA BAJO Y SOBRE LA RASANTE.
- PARCELA PRIVADA CONSTRUIDA BAJO RASANTE Y USO PRIVADO EN SUPERFICIE.
- PARCELA PRIVADA CONSTRUIDA BAJO RASANTE CON SERVIDUMBRE DE USO PUBLICO EN SUPERFICIE.
- PARCELA PRIVADA CONSTRUIDA BAJO Y SOBRE RASANTE CON SERVIDUMBRE DE USO PUBLICO EN PLANTA BAJA (PORCHES)
- PARCELA PRIVADA RAMPA DE ACCESO A GARAJE.

SUPERFICIES DEL AREA.

PARCELAS PRIVADAS.		11648 M2
1	2047 M2	
2	1935 M2	
3	1718 M2	
4	289 M2	
5	2141 M2	
6	1403 M2	
7	2115 M2	
ESPACIOS DE DOMINIO Y USO PUBLICO.		21075 M2
S.L. SISTEMA LOCAL DE ESPACIOS LIBRES		11438 M2
S.L. RED VIARIA		9637 M2
CALZADA Y APARCAMIENTOS	4219 M2	
ITINERARIOS Y ESPACIOS PEATONALES	5418 M2	
TOTAL AREA		32723 M2

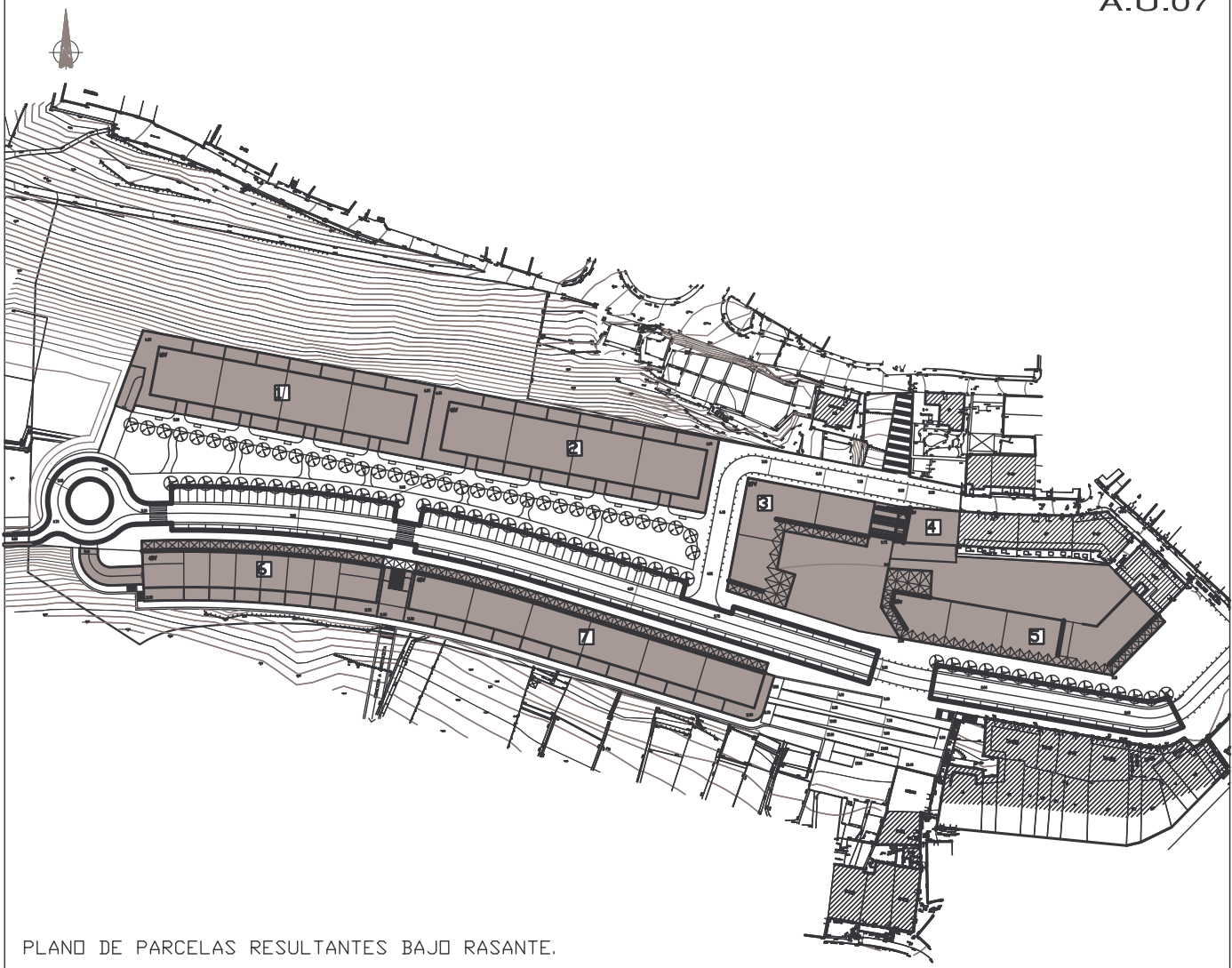

PLANO DE PARCELAS RESULTANTES BAJO RASANTE.

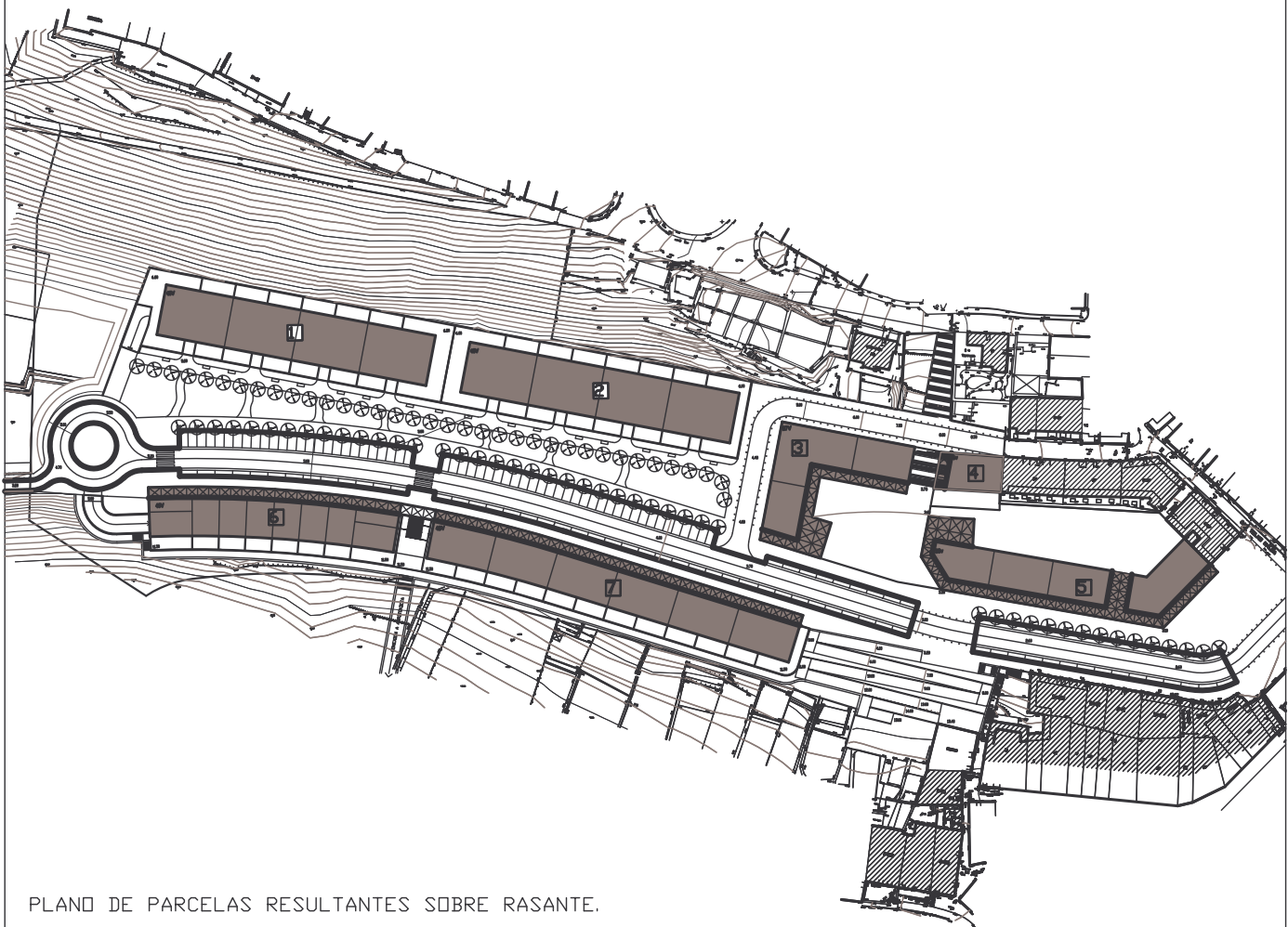

PLANO DE PARCELAS RESULTANTES SOBRE RASANTE.

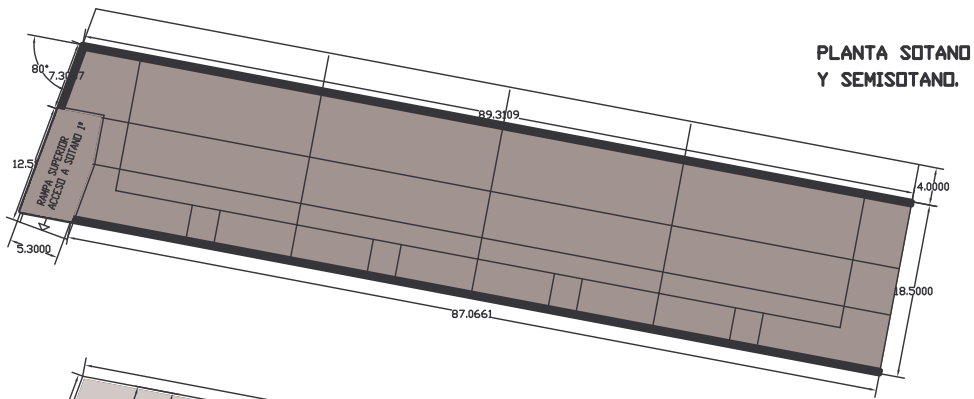

PLANTA SOTANO Y SEMISOTANO.

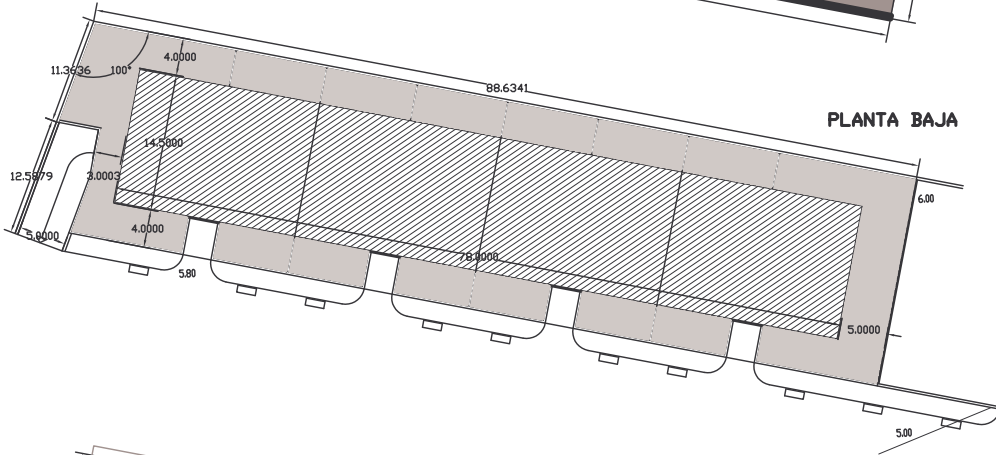

PLANTA BAJA

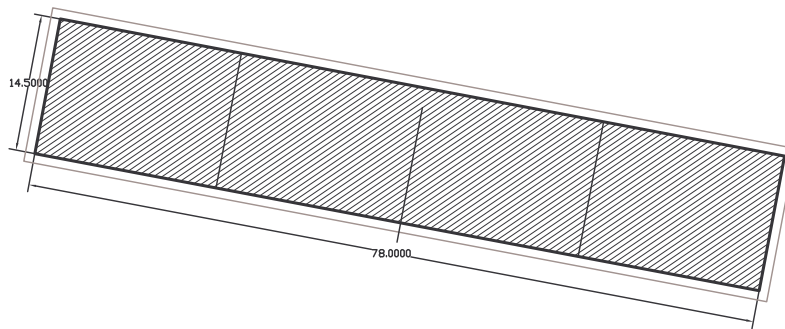

PLANTAS I, II y III.

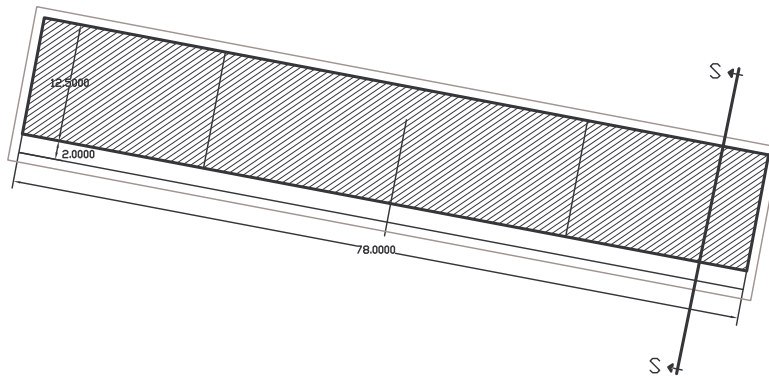

PLANTA RETRANQUEADA.

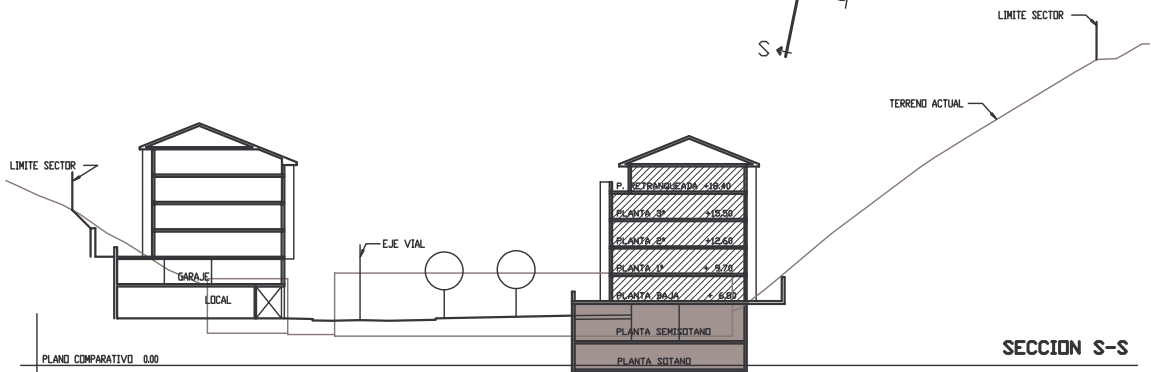

SECCION S-S

PARCELA 1.

SUPERFICIE SOLAR	2047 m ²
SUPERFICIE EDIFICABLE BAJO RASANTE	3305 m ²
SUPERFICIE EDIFICABLE SOBRE RASANTE	5880 m ²
NUMERO DE VIVIENDAS	40 ud
NUMERO MAXIMO DE PLANTAS	S+SS+PB+3P+R

- GARAJES EN SEMISOTANO
- VIVIENDAS
- TERRAZA PRIVADA PARA USO DE LA VIVIENDA EN PLANTA BAJA.

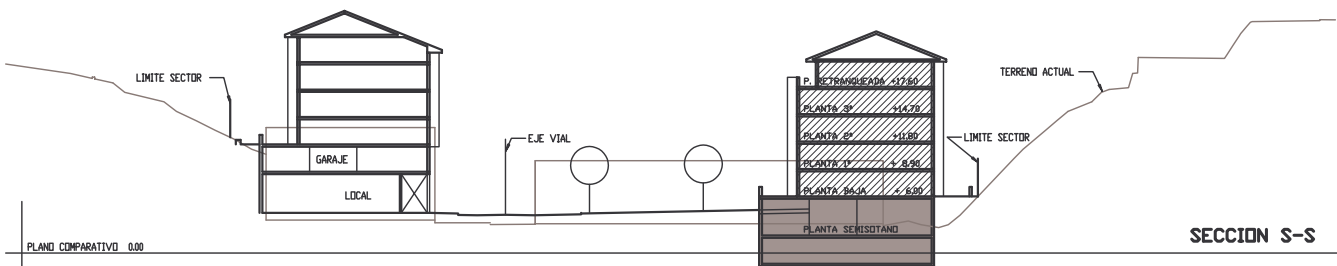
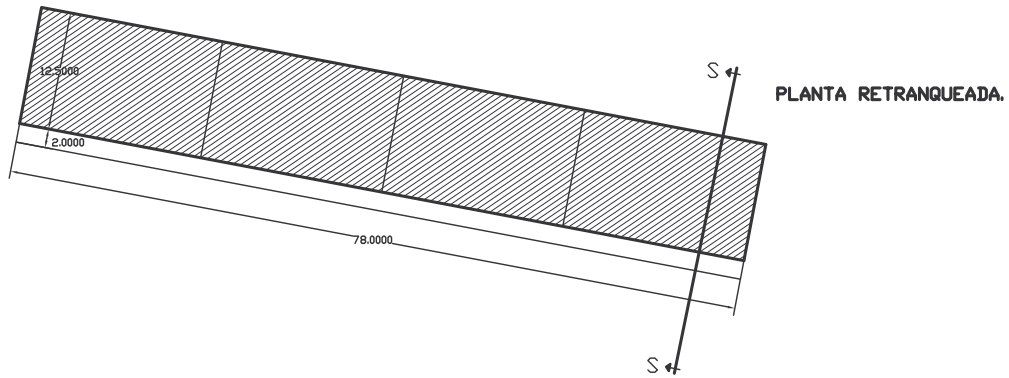
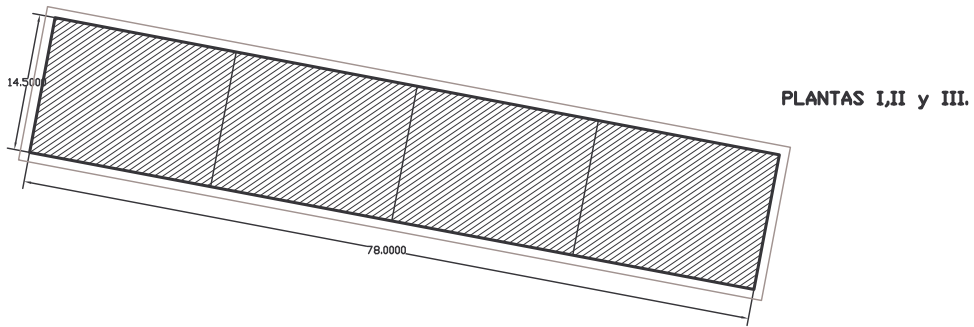
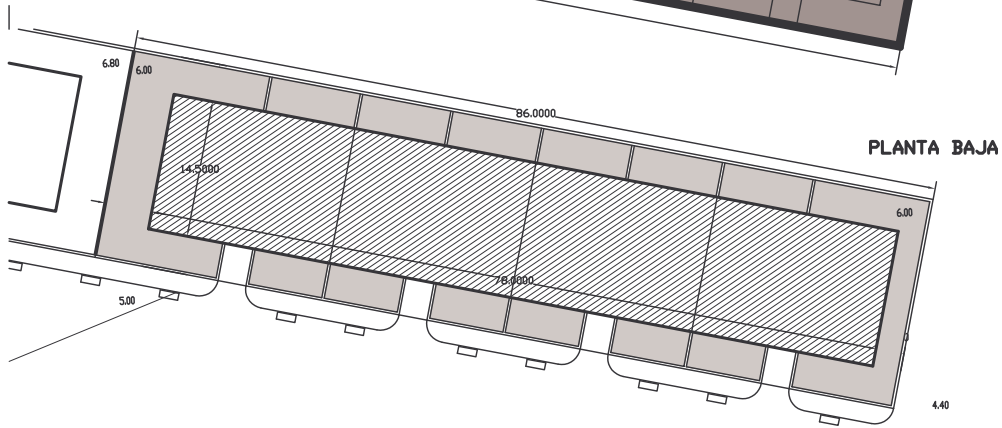
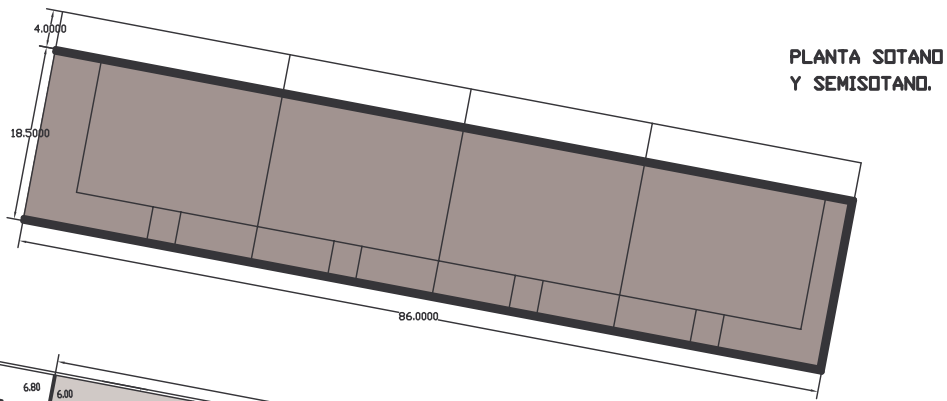

PARCELA 2.

SUPERFICIE SOLAR	1935 m ²
SUPERFICIE EDIFICABLE BAJO RASANTE	3182 m ²
SUPERFICIE EDIFICABLE SOBRE RASANTE	5880 m ²
NUMERO DE VIVIENDAS	40 ud
NUMERO MAXIMO DE PLANTAS	S+SS+PB+3P+R

-  GARAJES EN SEMISOTANO
-  VIVIENDAS
-  TERRAZA PRIVADA PARA USO DE LA VIVIENDA EN PLANTA BAJA.

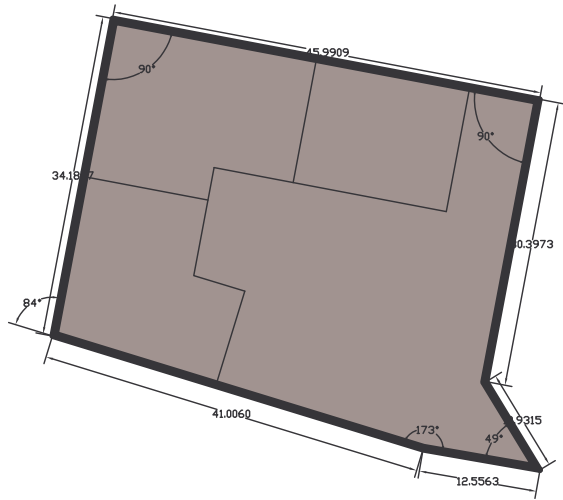

PLANTA SOTANO 1 y 2

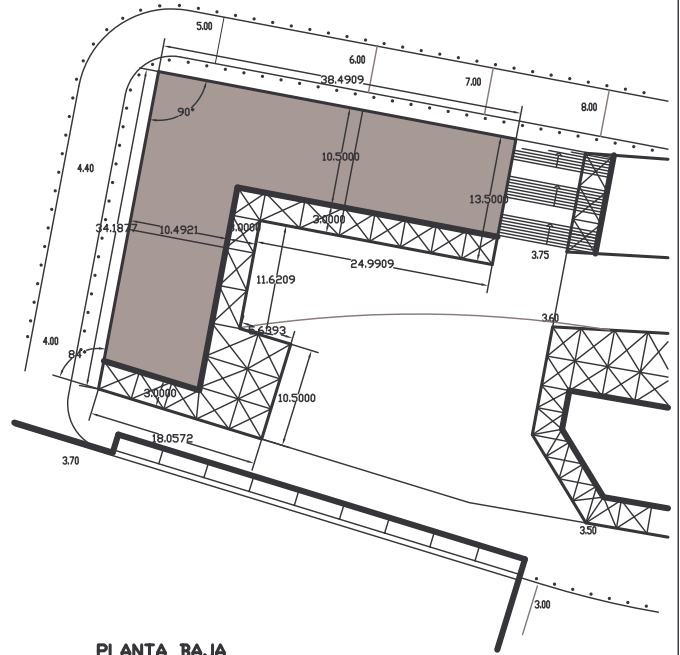

PLANTA BAJA

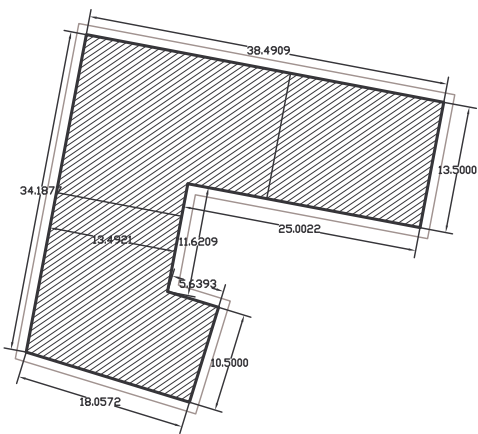

PLANTAS 1ª, 2ª y 3ª

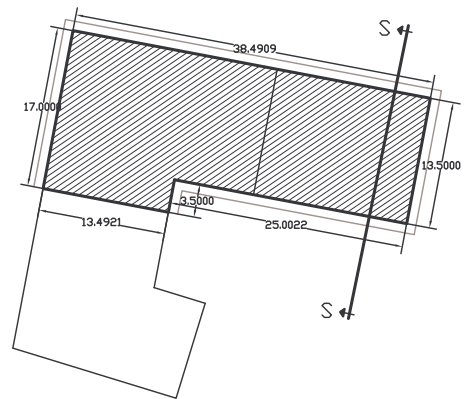

PLANTA 4ª

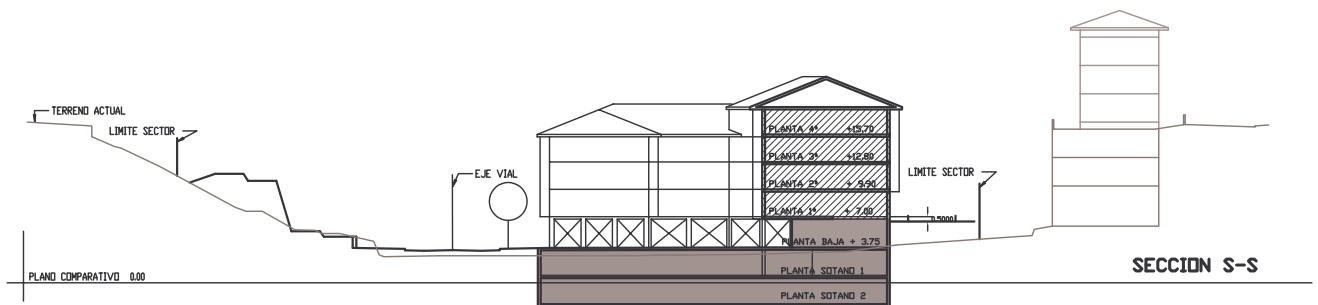

SECCION S-S

PARCELA 3.

SUPERFICIE SOLAR	1718 m ²
SUPERFICIE EDIFICABLE BAJO RASANTE	3436 m ²
SUPERFICIE EDIFICABLE SOBRE RASANTE	4327 m ²
NUMERO DE VIVIENDAS	27 ud
NUMERO MAXIMO DE PLANTAS	S+PB+4P

- GARAJES EN SOTANO
- SOPORTALES
- LOCALES COMERCIALES
- VIVIENDAS

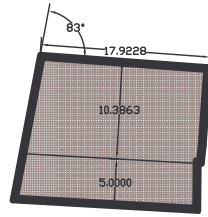

PLANTA SOTANO

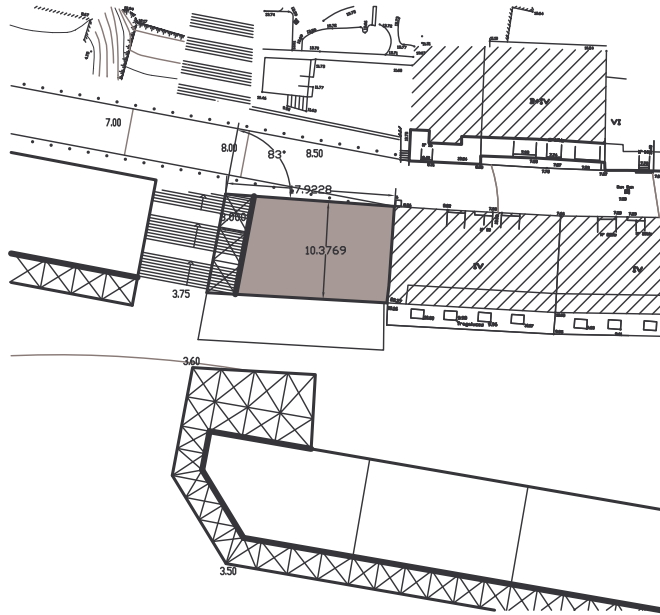

PLANTA BAJA Y ENTRPLANTA

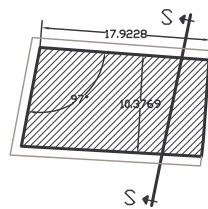

PLANTAS I,II y III.

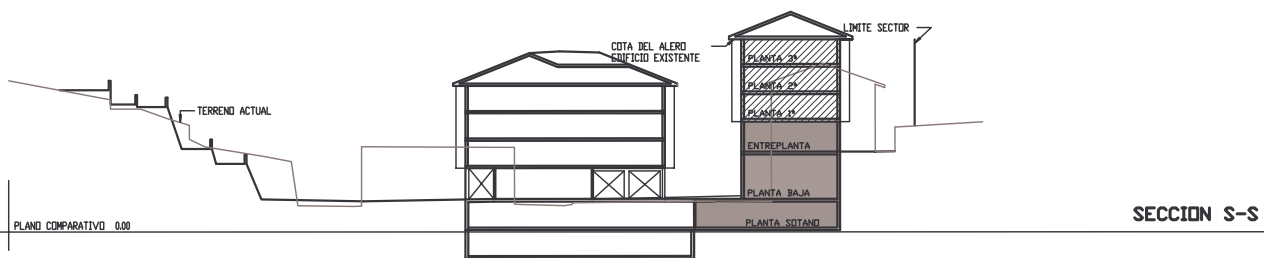

PARCELA 4.

SUPERFICIE SOLAR	289 m ²
SUPERFICIE EDIFICABLE BAJO RASANTE	289 m ²
SUPERFICIE EDIFICABLE SOBRE RASANTE	982 m ²
NUMERO DE VIVIENDAS	6 ud
NUMERO MAXIMO DE PLANTAS	S+PB+E+3P



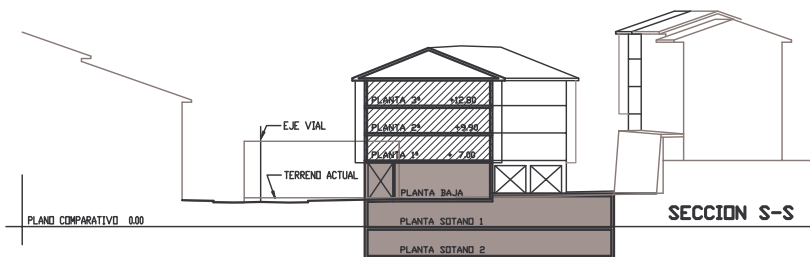
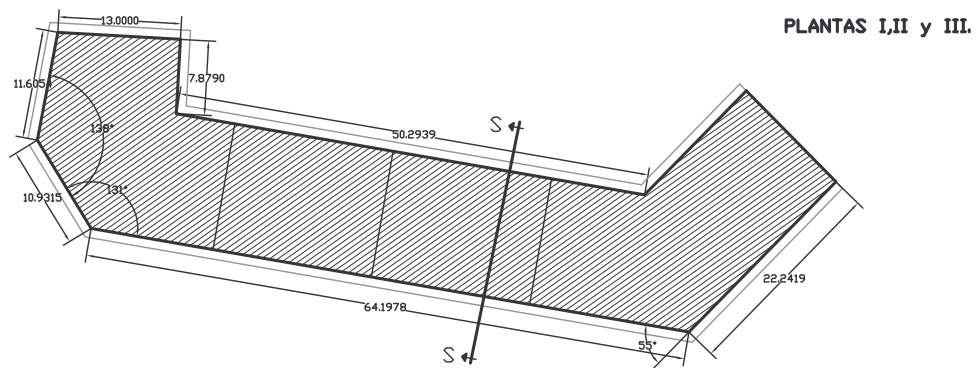
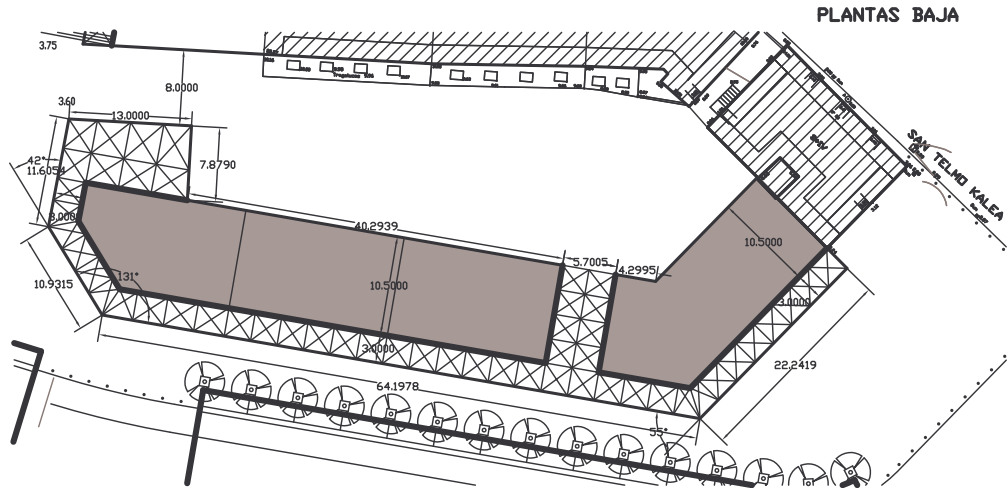
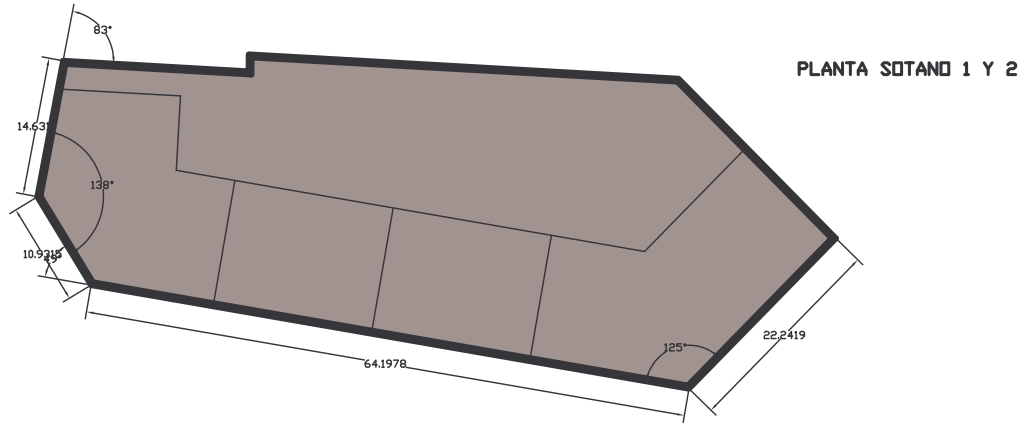

PARCELA 5.

SUPERFICIE SOLAR	2141 m ²
SUPERFICIE EDIFICABLE BAJO RASANTE	4282 m ²
SUPERFICIE EDIFICABLE SOBRE RASANTE	5338 m ²
NUMERO DE VIVIENDAS	33 udi
NUMERO MAXIMO DE PLANTAS	S+PB+3P

	GARA.JES		VIVIENDAS
	SOPORTALES		
	LOCALES COMERCIALES		

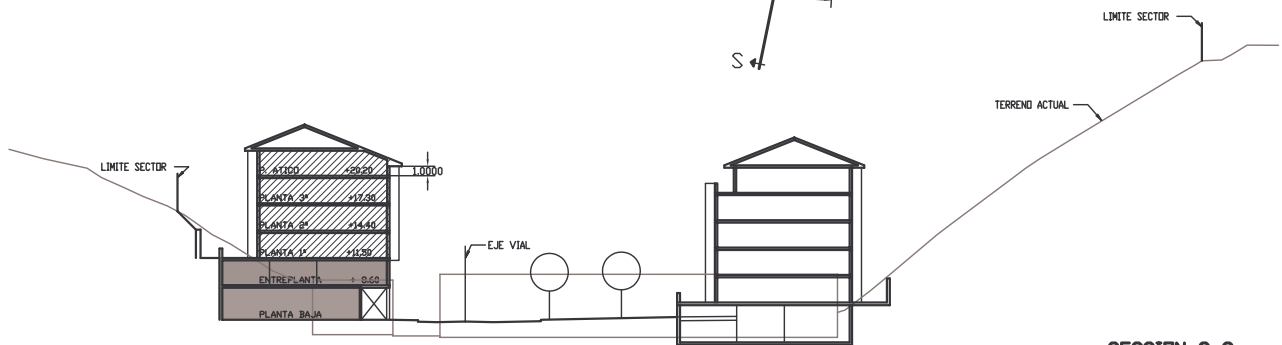
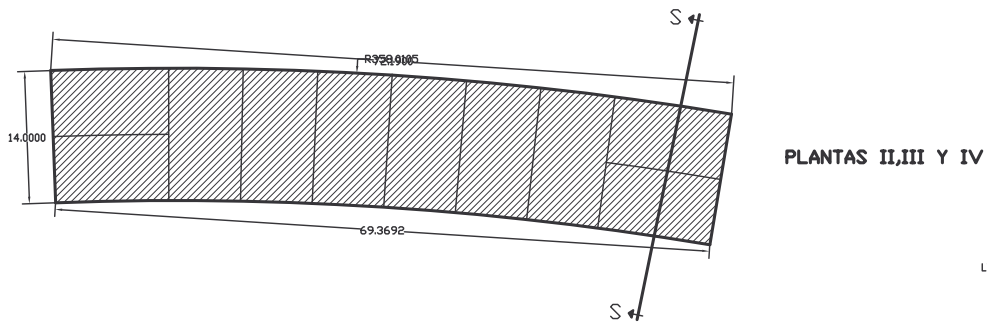
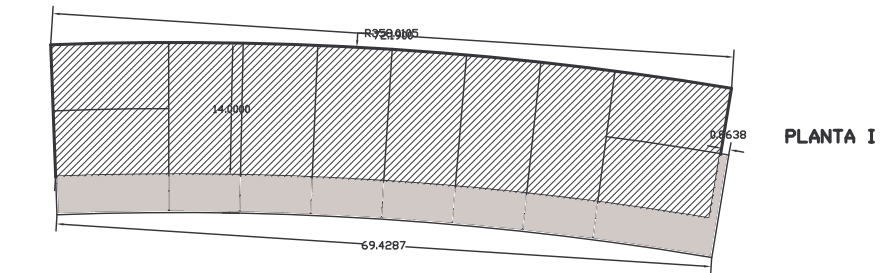
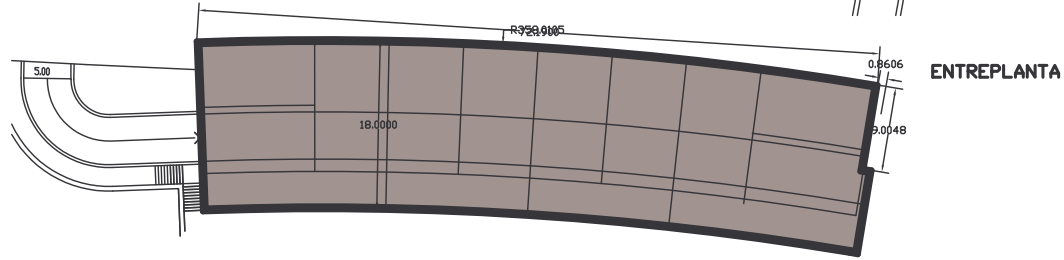
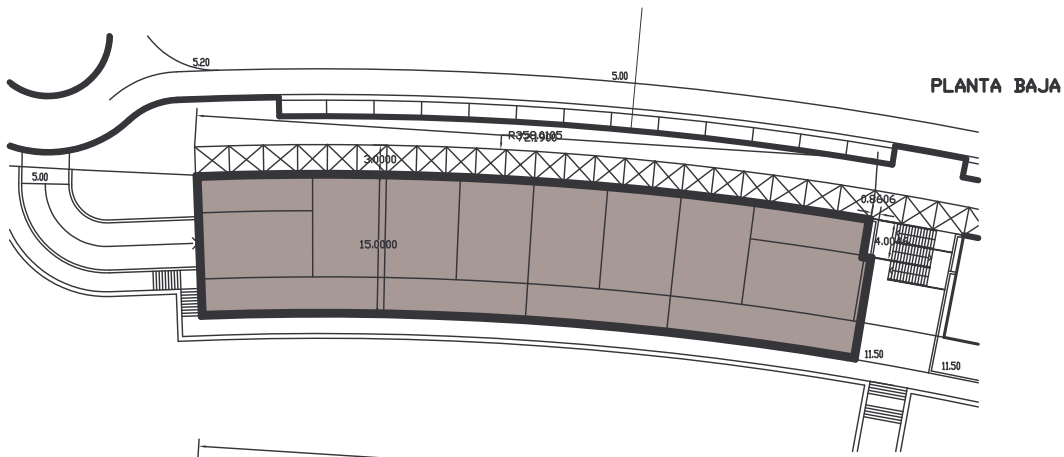

PLANO COMPARATIVO 0.00

SECCION S-S

PARCELA 6.

SUPERFICIE SOLAR	1403 m ²
SUPERFICIE EDIFICABLE BAJO RASANTE	—
SUPERFICIE EDIFICABLE SOBRE RASANTE	7040 m ²
NUMERO DE VIVIENDAS	40 ud
NUMERO MAXIMO DE PLANTAS	PB+E+3P+A



SOPORTALES



LOCALES COMERCIALES



GARAJES EN ENTREPLANTA



TERRAZA PRIVADA PARA USO DE LA VIVIENDA EN PLANTA 1ª



VIVIENDAS

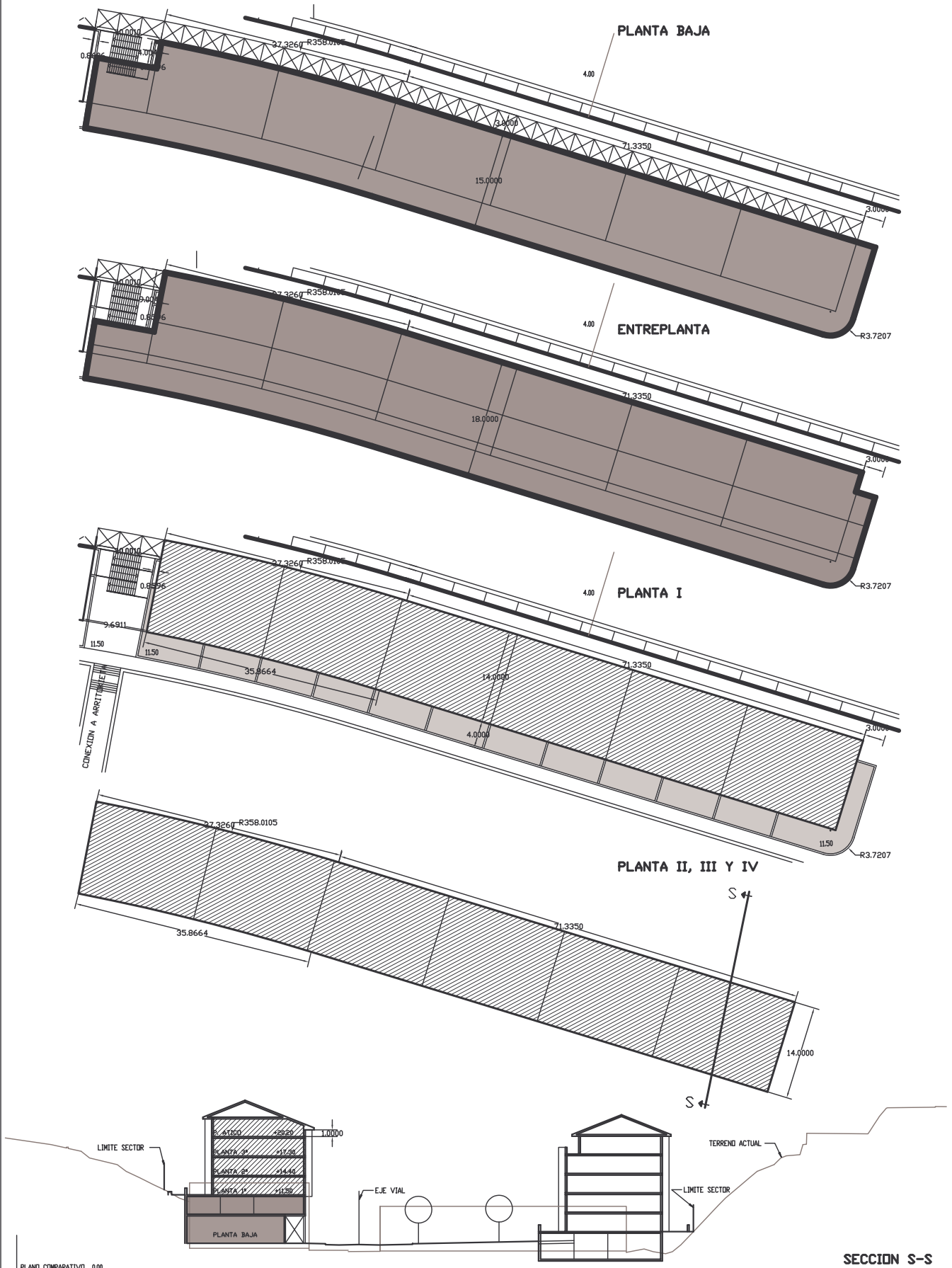

PARCELA 7.

SUPERFICIE SOLAR	2115 m ²
SUPERFICIE EDIFICABLE BAJO RASANTE	—
SUPERFICIE EDIFICABLE SOBRE RASANTE	10198 m ²
NUMERO DE VIVIENDAS	48 udl
NUMERO MAXIMO DE PLANTAS	PB+E+3P+A



SOPORTALES



LOCALES COMERCIALES



GARAJES EN ENTREPLANTA



TERRAZA PRIVADA PARA USO DE LA VIVIENDA EN PLANTA I.



VIVIENDAS